

SLAMMO V5

**DALI Type 6
MultiProtocol LED dimmer
for Constant Voltage LEDs**

User Manual

Issue: Oct 2024



Pictured: SLAMMO in IP54 enclosure – also available as OEM PCB or IP67

Supply for **L**ight Emitting Diodes **A**mplified **M**odulation **M**aximum **O**utput

Creative Lighting can be contacted through your local distributor.

Creative Lighting

4 Pine Street North Ipswich Queensland Australia 4305

Tel (+617) 32828777 Fax (+617) 32828700

Email: SLAMMO@creativelighting.com.au

SLAMMO V5 – Important Installation Considerations

The SLAMMO V5 in IP67 enclosures should be separated by an air gap of not less than 50mm for air movement around the case. Power supplies should also be separated from each other (refer to the power supply manufacturer's recommendations) and from the SLAMMOs, typically above the SLAMMOs and in any case separated by at least 50mm from the SLAMMOs. Care should be taken not to create significant EMI (electromagnetic interference) near SLAMMOs, and in particular, do not coil any spare wiring from the power supplies – always trim to length. Local interference may limit the number of SLAMMOs on one power supply and in any case a limit of six SLAMMOs powered by the same power supply is recommended. 24V_{DC} LED loads on SLAMMO OEM PCBs (no enclosure) can be up to 25A total load per SLAMMO and 15A *per output* of LEDs but these maximums must be de-rated to allow for the LED's inrush current at start up. These values must also be de-rated dependant on air movement/cooling (in air-conditioned environments kept at <40°C for example, the full rating is possible after allowance for any inrush current). The SLAMMO V5 (PCA and IP54 versions) located in an ambient of 40°C or less is suitable for loads up to 600W @24V_{DC} less the power supply inrush headroom (a suitable PSU such as the Meanwell HLG-600H-24 should only be loaded to <490W @ 24V_{DC}. The SLAMMO V5 (IP67 version) located in an ambient of <40°C is suitable for loads up to 450W @ 24 V_{DC}.

SLAMMO V5 – Important Connection Polarity and Voltage

The SLAMMO is designed to operate at 7-48V_{DC} (voltages above 60V_{DC} will result in damage). The voltage supplied to the SLAMMO should match the V_{DC} of the LEDs to be controlled, and not exceed 48V_{DC}. The SLAMMO V5 has reverse polarity protection, but damage may still occur to the connected load.

SLAMMO V5 – Matched power supplies

DO NOT use any power supply that is not compliant with CISPR15 (EN55015). We recommend approved CISPR 15 compliant power supplies by Meanwell (EG HLG and CLG series). Only one power supply per SLAMMO (or SLAMMOs) can be used – do NOT combine the outputs of more than one power supply. Note that the HLG-600 series have two paralleled output leads, each of which is rated at 20A. If only one output cable of an HLG-600 is used, the other must be properly terminated. If both outputs are used, they must be marshalled properly into a j box or similar.

IP67 Enclosure – Important: Temperature/Load

The SLAMMO V5 in IP67 enclosure should not be overloaded – the maximum recommended load is 450W at 24V_{DC} and 300W at 12V_{DC} in environments with ambient temperatures <40°C. For SLAMMO in IP67 enclosures, no channel should be loaded with more 10A to allow for inrush from the LEDs at start up. The total of all four outputs must not exceed 450W (18.75A at 24V_{DC} or 25A 300W at 12V_{DC}). It is recommended that channels be evenly loaded where possible. Optional vents are also available. Maximum design temperature of the SLAMMO V5 PCA is 70°C.

IP54 Enclosure – Important: Temperature/Load

The SLAMMO V5 in IP54 enclosure should not be overloaded – the maximum recommended load is 480W at 24V_{DC} and 360W at 12V_{DC} in environments with ambient temperatures <40°C. For SLAMMO in IP54 enclosures, no channel should be loaded with more 12A to allow for inrush from the LEDs at start up. The total of all four outputs must not exceed 480W (25A at 24V_{DC} or 30A at 12V_{DC}). It is recommended that channels be evenly loaded where possible. Maximum design temperature of the SLAMMO V5 PCA is 70°C.

Output Protection

Each of the 4 SLAMMO outputs are protected against short circuit by a 15A fuse. In the event that the output voltage is not as expected (and indicated by the mimic LED for that output), check for fuse failure caused by a short in your LED wiring or LEDs. Remedy any short first before replacing the fuse. The fuses on the 4 outputs are Littlefuse brand model 0451015.MRL available from Element14 and other major electronics components wholesalers.

Mimic LEDs

Each output has a mimic LED on the SLAMMO V5 PCA:

Output 1	RED
Output 2	GREEN
Output 3	BLUE
Output 4	WHITE

SLAMMO V5 - Description

The SLAMMO V5 can be controlled by DALI OR DSI OR DMX512 and RDM, though only by one of these protocols at a time. The currently active protocol can be selected using the 10-way dipswitch, which is accessible from the top of the case, or by using the RDM (Remote Device Management) interface (using a suitable RDM tool such as the Control Freak ADDICT). Note that the SLAMMO V5 will only listen to the currently active protocol and ignore the other protocols (although it will always listen and respond to RDM commands). The SLAMMO V5 suits the driving of constant voltage common anode LEDs.

Selecting protocol using Dipswitches

The currently active protocol for the SLAMMO can always be selected using the 10-way dipswitch:

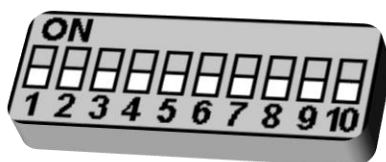

Up is ON, down is OFF

Selecting DALI with the dipswitches

To operate the SLAMMO V5 as a DALI device, turn switch 10 ON and leave all other switches OFF. The SLAMMO V5 will then immediately be able to respond to DALI levels and commands (and will use any persistent settings that have been previously programmed via DALI).

Selecting DSI with the dipswitches

To operate the SLAMMO V5 as a DSI device, turn switch 9 and 10 ON and leave all other switches OFF. The SLAMMO V5 will then immediately be able to respond to DSI levels. All outputs will be slaved in DSI mode.

Selecting Test mode with the dipswitches

To operate the SLAMMO V5 in test mode, turn switch 8, 9 and 10 ON. The SLAMMO V5 will then start sequencing Red, Green, Blue, White, Full Output and back to Red with a 4 second fade time.

Selecting DMX512 with the dipswitches

To operate the SLAMMO V5 as a DMX512 device, turn switch 10 OFF and use the other 9 switches to select the starting DMX512 address. The SLAMMO V5 will then immediately be able to respond to DMX512 levels. The valid range for the address is 1 to 508 and is selected as a binary number with switches 1 to 9:

Switch	1	2	3	4	5	6	7	8	9
Value	1	2	4	8	16	32	64	128	256

The starting DMX512 address is the sum of the values for the switches that are currently ON. Any changes to the state of the switches will immediately update the address, and the SLAMMO V5 will start responding to the new address straight away.

E.g. For an address of 267, break the value down into its components by removing the largest value.

$267 - 256 = 11$ – Turn Bitswitch 9 on

The next smallest is 4 (Value 8), so Bitswitch 5,6,7, and 8 should be left off.

$11 - 8 = 3$ – Turn Bitswitch 4 on

Leave Bitswitch 3 on

$3 - 2 = 1$ – Turn Bitswitch 2 on

$1 - 1 = 0$ – Turn Bitswitch 1 on.

Therefore, $267 = 0b110100001$. You can also use Microsoft Calculator on 'Programming Mode' to easily get this value. Make sure to reverse the value on the calculator as the SLAMMO is LSB first.

Selecting the active protocol with RDM

To select the active protocol using the RDM interface, turn all switches OFF. The protocol that was already programmed using RDM will then immediately be active and the SLAMMO V5 will start responding to levels and/or commands for that protocol. For details on programming the active protocol using RDM, see the RDM interface at the end of this Manual. Note that the default factory setting for RDM protocol is DALI.

2-Way Bitswitches – DMX512

The 2-way bitswitches are designed for use in applications that use DMX512 (& RDM) and are not used with DALI or DSI.



2-way bitswitch #1 is located furthest from the 3 large aluminium heatsinks. 2-way bitswitch #2 is located nearest the 3 large aluminium heatsinks.

In DMX512 applications:

- 2-way bitswitch #1 - For use with **unshielded** Cat 5 or higher network cables connected to the SLAMMO's RJ45 sockets
 - Bitswitch 1 - turn this bitswitch on to connect the DMX ground to the SLAMMO ground (via the integral 100Ω resistor) IF there is unavoidable excessive EMI noise interfering with operation
 - Bitswitch 2 - turn this bitswitch on to connect the DMX Data + and Data – to the SLAMMO's integral 120Ω resistor IF this SLAMMO is the last DMX512 device on a given DMX512 line
- 2-way bitswitch #2 - For use with **shielded** Cat 5 or higher network cables connected to the SLAMMO's RJ45 sockets
 - Bitswitch 1 - turn this bitswitch on to connect the network cable's shield to the SLAMMO's DMX ground (Pins 7 & 8) IF there is unavoidable excessive EMI noise interfering with operation
 - Bitswitch 2 - turn this bitswitch on to connect the **shielded** Cat 5 (or higher) network cable's shield to the SLAMMO's ground (Pins 7 & 8) through the SLAMMO's integral 100 Ω resistor IF there is unavoidable excessive EMI noise interfering with operation

DALI Operation

The SLAMMO V5 complies with DALI version 2 and implements four standard DALI devices (In standard configuration), with one DALI address per output as standard. The amount of DALI devices is selectable via RDM from 1, 2, 3, or 4 (default). The SLAMMO reacts to all DALI Type 6 Commands including fast fade time facilities and dimming curve selection. To receive DALI levels and commands, the DALI terminals of the SLAMMO V5 should be connected to a DALI line that also connects to a DALI power supply unit and one or more DALI controllers. For more information on the DALI protocol, refer to the DALI Standard documentation. The SLAMMO will react to correct DALI voltage between 9.5V and 22.5V with a threshold of 8.0V. The DALI Receiver will receive messages with a slightly wider timing range than required to prevent missing messages.

DALI Fade Time

The DALI fade time allows for the device to set (per channel) a fade time based on Table 1. DALI Fade Times. Note: A DALI fade time will only be used with **Direct Arc Level** Commands; as per the DALI standard, a MAX, MIN or OFF command will use the device's fast fade time value (Default – Instant).

Table 1. DALI Fade Times

Fadetime Setting	Min fade time (s)	Nominal fade time (s)	Max fade time (s)
0	Uses Extended Fade Time – see Extended Fade Times		
1	0.6	0.7	0.8
2	0.9	1.0	1.1
3	1.3	1.4	1.6
4	1.8	2.0	2.2
5	2.5	2.8	3.1
6	3.6	4.0	4.4
7	5.1	5.7	6.2
8	7.2	8.0	8.8
9	10.2	11.3	12.4
10	14.4	16.0	17.6
11	20.4	22.6	24.9
12	28.8	32.0	35.2
13	40.7	45.3	49.8
14	57.6	64.0	70.4
15	81.5	90.5	99.6

Extended Fade Times

Version 2 of the DALI standard allows for a much greater variety of fadetimes than those shown above for older versions. If the fade time of 0 is selected, then the device will use the extended fade rate to calculate the desired fade. The value that is sent to the device is calculated using the equation (1), where AAAA is the base value, (between 1 and 16) and YYY is the fade time multiplier. The multipliers are shown in Table 2. DALI Extended Fade Multipliers.

$$0YYYYAAAAb \quad (1)$$

Table 2. DALI Extended Fade Multipliers

Multiplier (YYY)	Multiplication Factor		
	Minimum	Nominal	Maximum
000b	0ms	0ms	0ms
001b	95ms	100ms	105ms
010b	0.95s	1s	1.05s
011b	9.5s	10s	10.5s
100b	0.95 min	1 min	1.05 min

Example: If you want to set a fade rate of 6 minutes then you would calculate it as shown below;

$$AAAA = 6 = 0101 \text{ (binary)}$$

$$YYY = 100 \text{ (binary)}$$

$$\text{Byte to send} = 0YYYAAAA = 01000101 = 69 \text{ (Dec)} = 0x45 \text{ (Hex)}$$

This fade rate allows for fades between 100ms to 16 minutes.

Fast Fade Time

If both the fade time and the extended fade time are set to 0, then the device will use its fast fade time. The fast fade times are shown in the Table 3. Fast Fade Times.

Table 3. Fast Fade Times

No#	Time (ms)	No#	Time (ms)	No#	Time (ms)	No#	Time (ms)
0	< 25 (5ms)	7	175	14	350	21	525
1	25	8	200	15	375	22	550
2	50	9	225	16	400	23	575
3	75	10	250	17	425	24	600
4	100	11	275	18	450	25	625
5	125	12	300	19	475	26	650
6	150	13	325	20	500	27	675

The default fast fade time is 0, where the change in light level will be performed at the SLAMMOs highest rate (approx. < 5ms).

Dimming Curve

The SLAMMO V5 Type 6 allows for the selection of an appropriate dimming curve; logarithmic or linear. The default mode is logarithmic. The dimming curve can be selected through the device type 6 extended command 227, where a value of 0 represents logarithmic, and a value of 1 represents linear. The difference between the curves is shown in Figure 1. Log and Linear Dimming Curves.

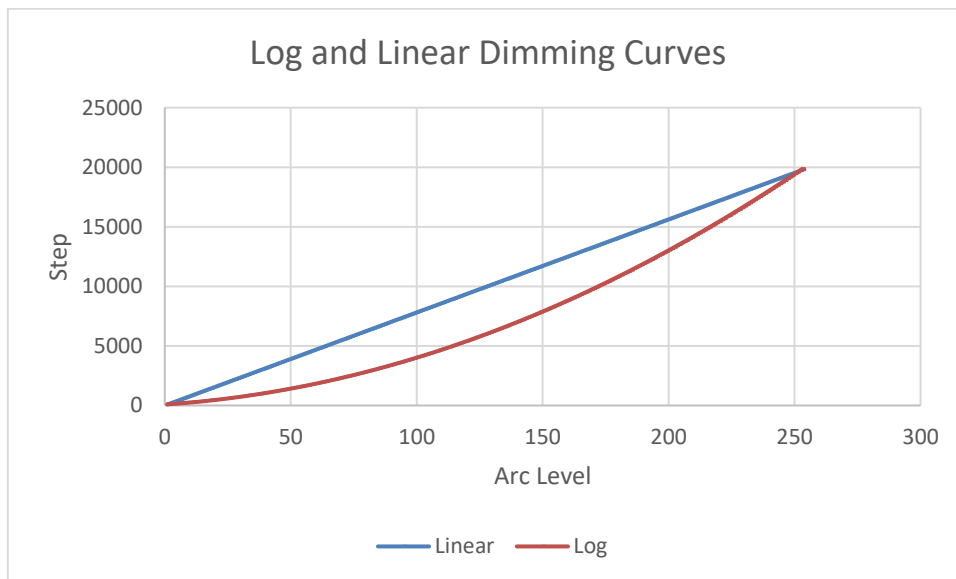

Figure 1. Log and Linear Dimming Curves

Type 6 DALI

The SLAMMO is designed for DALI Type 6 and follows as per the standard commands in Table 4. Type 6 Commands. The expected responses are outlined, as well as the supported features of type 6.

Command Number	Name	Supported	Response
224	Reference System Power	NO	No Response
225	Enable Current Protection	NO	No Response
226	Disable Current Protection	NO	No Response
227	Select Dimming Curve	YES	No Response
228	Store DTR Fast Fade Time	YES	No Response
229	Reserved		
230-231	Reserved		
232-235	Reserved		
236	Reserved		
237	Query Gear Type	YES	0x08
238	Query Dimming Curve	YES	0 or 1
239	Query Possible Operating Modes	YES	0x01
240	Query Features	YES	0x00
241	Query Failure Status	YES	0x80
242	Query Short Circuit	NO	No Response
243	Query Open Circuit	NO	No Response
244	Query Load Decrease	NO	No Response
245	Query Load Increase	NO	No Response
246	Query Current Protection Active	NO	No Response
247	Query Thermal Shut Down	NO	No Response
248	Query Thermal Overload	NO	No Response
249	Query Reference Running	NO	No Response
250	Query Reference Measurement failed	NO	No Response
251	Query Current Protection Enabled	NO	No Response
252	Query Operating Mode	YES	0x00
253	Query Fast Fade Time	YES	Value 0-27
254	Query Min Fast Fade Time	YES	0x00
255	Query Extended Version Number	YES	0x01
272	Enable Device Type 6	SPECIAL	No Response

Table 4. Type 6 Commands

In order to send a Type 6 command, the Enable Device Type 6 command must be sent first, and then the desired command. The Type 6 command must also be repeated within 100ms in order for it to be successfully read. The 'Enable Device Type 6' command must be sent before every type 6 command; it does not enable it indefinitely and is disabled on any other command received.

Miscellaneous

The SLAMMO V5 contains a memory bank that has information such as UID (Unique Identifier), DALI version, Hardware version and software version. This information is all available through reading the memory bank through DALI. Note; The UID number presented in the memory bank is the same as the RDM UID.

DSI Operation

The SLAMMO V5 implements a single DSI device – i.e. 4 channels act as 1. To receive DSI levels, the DALI terminals of the SLAMMO V5 should be connected to a DSI bus/line that also connects to a DSI controller. For more information on the DSI protocol, refer to DSI Protocol documentation.

DMX₅₁₂ Operation

The SLAMMO V5 implements four DMX₅₁₂ devices in the one SLAMMO to allow individual control over all four outputs. Depending on its current personality the SLAMMO V5 will have a DMX₅₁₂ footprint (i.e. how many channels it listens to) of 4, 8, 12, 16, or 5 channels as set out below.

DMX512 Personalities

This section outlines the five personalities that are available for DMX₅₁₂ in the SLAMMO V5, programmable by means of RDM-compliant devices such as the Control Freak ADDICT®.

Personality 1 – Basic

This personality provides the simplest DMX₅₁₂ functionality for the SLAMMO V5. This is the default personality, which provides simple single channel per output DMX₅₁₂ dimming. The following table lists the DMX₅₁₂ channels that the SLAMMO V5 listens to for the basic personality:

DMX channel if Start Address is DMX Channel 1	Personality 1		
	Offset from Start Address	Channel name	Output
1	+ 0	Coarse	Ch 1
2	+1	Coarse	Ch 2
3	+2	Coarse	Ch 3
4	+3	Coarse	Ch 4

Personality 2 – Intermediate (vector)

This personality adds to the functionality of the basic personality, providing a means of achieving smoother dimming. DMX₅₁₂ is limited to a refresh rate of 44HZ as it services all 512 channels 44 times per second. Vector mode removes this limitation by handing over fading to the SLAMMO V5 which increase the refresh rate (fade updates) to 200Hz. (This should not be confused with the on/off frequency of the LEDs which is 400Hz standard and 800Hz optional). The following table describes the function for each DMX₅₁₂ channel that the SLAMMO V5 listens to for the intermediate personality:

DMX channel if Start Address is DMX Channel 1	Personality 2		
	Offset from Start Address	Channel name	Output
1	+ 0	Coarse	Ch 1
2	+ 1	Vector	Ch 1
3	+ 2	Coarse	Ch 2
4	+ 3	Vector	Ch 2
5	+ 4	Coarse	Ch 3
6	+ 5	Vector	Ch 3
7	+6	Coarse	Ch 4
8	+7	Vector	Ch 4

This personality allows for an individual DMX₅₁₂ channel for the vector control of each output. For a global vector mode that allows a single DMX₅₁₂ channel for the vector control of all four outputs, refer to Personality 5 overleaf.

Personality 3 – Advanced

This personality adds to the functionality of the intermediate personality, providing another means of achieving smoother dimming, allowing either vector mode or coarse (8 bit) and fine (16 bit) dimming. The following table describes the function for each DMX₅₁₂ channel that the SLAMMO V5 listens to for the advanced personality:

Personality 3			
DMX channel if Start Address is DMX Channel 1	Offset from Start Address	Channel name	Output
1	+ 0	Coarse	Ch 1
2	+ 1	Fine	Ch 1
3	+ 2	Vector	Ch 1
4	+ 3	Coarse	Ch 2
5	+ 4	Fine	Ch 2
6	+ 5	Vector	Ch 2
7	+ 6	Coarse	Ch 3
8	+ 7	Fine	Ch 3
9	+ 8	Vector	Ch 3
10	+ 9	Coarse	Ch 4
11	+ 10	Fine	Ch 4
12	+ 11	Vector	Ch 4

Personality 4 – Advanced with Strobe

This personality adds another channel to the advanced personality, providing an automatic strobe function. The following table describes the function for each DMX₅₁₂ channel for advanced with strobe personality:

Personality 4			
DMX channel if Start Address is DMX Channel 1	Offset from Start Address	Channel name	Output
1	+ 0	Coarse	Ch 1
2	+ 1	Fine	Ch 1
3	+ 2	Vector	Ch 1
4	+ 3	Strobe	Ch 1
5	+ 4	Coarse	Ch 2
6	+ 5	Fine	Ch 2
7	+ 6	Vector	Ch 2
8	+ 7	Strobe	Ch 2
9	+ 8	Coarse	Ch 3
10	+ 9	Fine	Ch 3
11	+ 10	Vector	Ch 3
12	+ 11	Strobe	Ch 3
13	+ 12	Coarse	Ch 4
14	+ 13	Fine	Ch 4
15	+ 14	Vector	Ch 4
16	+ 15	Strobe	Ch 4

Personality 5 – Basic with Global Vector

This personality adds to the functionality of the basic personality, providing a means of achieving smoother dimming similar to Personality 2 but with less control channels required (5 instead of 8). DMX₅₁₂ is limited to a refresh rate of 44HZ as it services all 512 channels 44 times per second. Vector mode removes this limitation by handing over fading to the SLAMMO V5 which increase the refresh rate (fade updates) to 200Hz. (This should not be confused with the on/off frequency of the LEDs which is 400Hz standard and 800Hz optional). The following table describes the function for each DMX₅₁₂ channel that the SLAMMO V5 listens to for the intermediate personality:

	Personality 1		
DMX channel if Start Address is DMX Channel 1	Offset from Start Address	Channel name	Output
1	+ 0	Coarse	Ch 1
2	+ 1	Coarse	Ch 2
3	+2	Coarse	Ch 3
4	+ 3	Coarse	Ch 4
5	+ 4	Vector	Ch ALL

DMX512 Control Channel Functions

This section outlines the functionality for each of the DMX₅₁₂ channels that are available in the SLAMMO V5. Note that the number of channels that is available depends upon the current personality (see previous section).

Coarse Channel

This channel sets the current output intensity. It provides a 0-255 range of levels between 0% and 100% intensity. It is effectively '8-bit', and recommended only when the DMX₅₁₂ controller has limited functionality.

Fine Channel

This channel allows for greater control over the current output intensity. It provides up to a further 0-255 range of intensity levels between the current coarse output level and the next highest coarse output level. When dimming using the fine channel, the coarse and the fine levels should be treated as one value (ranging from 0-65535) and then split into two bytes when sending the DMX₅₁₂ levels. Not all controllers have this functionality (sometimes called 16-bit dimming).

Vector Channel

This channel allows the user to use a DMX₅₁₂ channel to determine the fadetime for the output intensity when the coarse and/or fine channels are changed. The following table outlines the functionality for different vector channel levels:

Channel level	Vector effect
0 – 5	No effect. Output will change as fast as the coarse/fine levels change.
5 – 255	Dimming rate is limited, ranging from fast (5) to slow (255). Exact rates of change are given in the next table.

The following table gives precise rates for each of the vector channel levels. Instead of specifying the rates in terms of something like output levels per second, the table shows how long it would take for the output intensity to change from 0% to 100% (or vice-versa), since this is typically a more useful way of describing the rates of change.

Channel level	Effective full-range time	Increments
0 – 5	Instant	
6 – 44	0.1s – 3.9s	0.1s
45 – 74	4s – 9.8s	0.2s
75 – 114	10s – 29.5s	0.5s
115 – 144	30s – 59s	1s
145 – 174	60s – 118s	2s
175 – 255	120s – 600s	6s

Example 1: You want to dim up over 1 second from 0 to 100% (ie the coarse channel changes from 0 to 255 and you want it to take 1 second). The vector channel would be **15** (falls in the range 0.1s – 3.9s which starts at 6, and it's 9 x 0.1s greater than 0.1s, which gives 6 + 9 = **15**).

Example 2: The coarse channel changes from a DMX₅₁₂ level of 201 to a level of 100 and you want it to take 30 seconds to dim down from 201 to 100. The table above provides times based on a change of 255 (0 to 100%), and you want to work out what vector level to use based on 201 – 100 = 101 out of 255. The closest equivalent in the table of full-range times would be 30 * (255/101) ≈ 76s, so the vector channel would be **153** (falls in the range 60s – 118s which starts at a level of 145, and it's 8 x 2s greater than 60s, which gives 145 + 8 = **153**).

Strobe Channel

This channel allows for the SLAMMO V5 to automatically strobe at a selectable frequency and intensity. The following table outlines the functionality for different strobe channel levels:

Channel level	Function	Idle/Strobe Intensity
0 – 7	No strobe	Always current intensity
8 – 15	One-shot strobe waiting zone	Always 0%, no strobing
16 – 23	One-shot strobe trigger zone	Idle 0%, strobe current
24 – 129	Variable frequency strobe, 0.1Hz – 10Hz	Idle 0%, strobe current
130 – 139	One-shot strobe waiting zone	Always current, no strobing
140 – 147	One-shot strobe trigger zone	Idle current, strobe 100%
148 – 255	Variable frequency strobe, 0.1Hz – 10Hz	Idle current, strobe 100%

In the table, “current intensity” refers to the output level selected by the coarse, fine and vector channels. A “one-shot” is a single strobe that occurs when the channel level moves from the “waiting zone” to the one-shot “trigger zone”. This allows for a controller to cause a strobe to occur at irregular intervals (instead of manually changing the output level), as demonstrated in the following diagram:

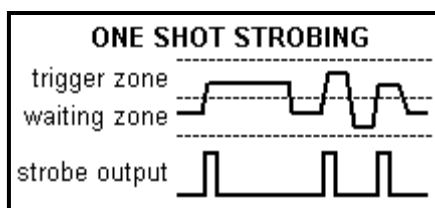

The strobe functionality for levels 8 – 131 is the same as 132 – 255, but has different idle and strobe intensities. A curve of the variable strobe frequency for different strobe channel levels is shown below.

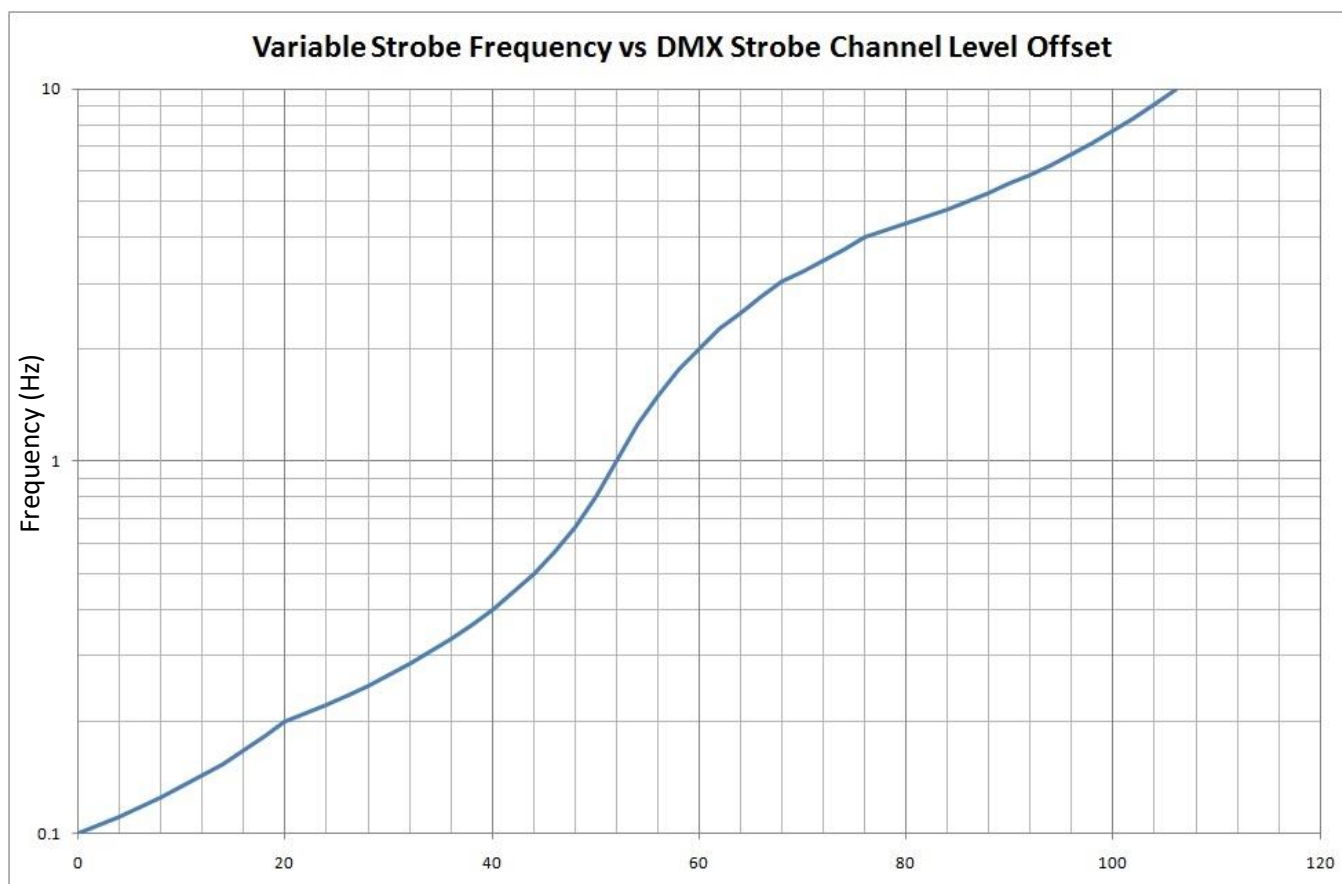

RDM Interface

1 Introduction

Remote Device Management protocol support has been implemented in the Control Freak SLAMMO V5. This document describes specific aspects of the RDM implementation. This document should be read in conjunction with the RDM specification.

2 Commands Supported

The following RDM parameters are implemented by the SLAMMO

RDM Parameter ID	Value	RDM Parameter ID	Value
DISC_UNIQUE_BRANCH	0x0001	DEVICE_LABEL	0x0082
DISC_MUTE	0x0002	FACTORY_DEFAULTS	0x0090
DISC_UN_MUTE	0x0003	SOFTWARE_VERSION_LABEL	0x00C0
SUPPORTED_PARAMETERS	0x0050	DMX_PERSONALITY	0x00E0
PARAMETER_DESCRIPTION	0x0051	DMX_PERSONALITY_DESCRIPTION	0x00E1
DEVICE_INFO	0x0060	DMX_START_ADDRESS	0x00F0
DEVICE_MODEL_DESCRIPTION	0x0080	IDENTIFY_DEVICE	0x1000
MANUFACTURER_LABEL	0x0081		

Additionally, the SLAMMO supports the following non-standard RDM parameters:

RDM Parameter ID	GET Allowed	SET Allowed	Value
Device Mode	✓	✓	0x8000
Device Curve	✓	✓	0x8004
Device Output Type	✓	✓	0x8005
Device Invert	✓	✓	0x8006
PWM Dithering	✓	✓	0x8007
Start-up Level	✓	✓	0x8008
Global Max	✓	✓	0x8009
Global Min	✓	✓	0x800A

3 SLAMMO V5 RDM Specific Parameter Descriptions

3.1 Device Mode

Parameter ID **0x8000**. This parameter sets the operating mode the device will use when not manually selected. When requesting the device mode, the effective device mode is returned (if overridden using the dipswitches).

3.1.1 Get Device Mode

Controller:

(CC) GET_COMMAND	(PID) Device Mode = 0x8000	(PDL) 0x00
(PD) Not Present		

Responder:

(CC) GET_COMMAND_RESPONSE	(PID) Device Mode = 0x8000	(PDL) 0x01
(PD) BYTE[0] 0: DMX512 1: DALI 2: DSI		

3.1.2 Set Device Mode

Controller:

(CC) SET_COMMAND	(PID) Device Mode = 0x8000	(PDL) 0x01
(PD) BYTE[0] 0: DMX512 1: DALI 2: DSI		

Responder:

(CC) SET_COMMAND_RESPONSE	(PID) Device Mode = 0x8000	(PDL) 0x00
(PD) Not Present		

3.2 Device Curve

Parameter ID **0x8004**. This parameter sets the operating curve between linear and logarithmic. The default device mode is logarithmic.

3.2.1 Get Device Curve

Controller:

(CC) GET_COMMAND	(PID) Device Curve = 0x8004	(PDL) 0x00
(PD) 0: Channel		

Responder:

(CC) GET_COMMAND_RESPONSE	(PID) Device Curve = 0x8004	(PDL) 0x01
(PD) BYTE[0] 0: Logarithmic 1: Linear		

3.2.2 Set Device Curve

Controller:

(CC) SET_COMMAND	(PID) Device Curve = 0x8004	(PDL) 0x01
(PD) BYTE[0] 0: Channel BYTE[1] 0: Logarithmic, 1: Linear		

Responder:

(CC) SET_COMMAND_RESPONSE	(PID) Device Curve = 0x8004	(PDL) 0x00
(PD) Not Present		

To see the difference between the curves refer to Figure 1. Log and Linear Dimming Curves

3.3 Device Output Type

Parameter ID **0x8005**. This parameter sets the output type of the SLAMMO V5. The default mode is 4 DALI/DMX Addresses controlling 4 Individual Outputs.

Output Type	Input	Output	Note
Normal	4	4 Individual	Normal Operation
Single	1	4 Together	Single Address controlling all outputs
White	2	2 Pairs	Input 1 controls Output 1 and 3, Inputs 2 controls output 2 and 4
RGB	3	3 Individual	Channels 1, 2, 3 Only (4 th output is spare/idle). (Reduces number of DALI addresses to 3)

3.3.1 Get Output Type

Controller:

(CC) GET_COMMAND	(PID) Device Output Type = 0x8005	(PDL) 0x00
(PD) Not Present		

Responder:

(CC) GET_COMMAND_RESPONSE	(PID) Device Output Type = 0x8005	(PDL) 0x01
(PD) BYTE[0] 0: Normal Operation 1: Single Channel 2: White 3: RGB		

3.3.2 Set Device Output Type

Controller:

(CC) SET_COMMAND	(PID) Device Output Type = 0x8005	(PDL) 0x01
(PD) BYTE[0] 0: Normal, 1: Single, 2: White, 3: RGB		

Responder:

(CC) SET_COMMAND_RESPONSE	(PID) Device Output Type = 0x8005	(PDL) 0x00
(PD) Not Present		

3.4 Device Invert

Parameter ID **0x8006**. This parameter sets the device mode so that the outputs' PWM is inverted. This is for fixtures that requires flipped PWM – i.e. 0 for 100% Brightness, and PWM of 100% for 0% Brightness.

3.4.1 Get Device Invert

Controller:

(CC) GET_COMMAND	(PID) Device Invert = 0x8006	(PDL) 0x00
(PD) Not Present		

Responder:

(CC) GET_COMMAND_RESPONSE	(PID) Device Invert = 0x8006	(PDL) 0x01
(PD) BYTE[0] 0: Normal 1: Inverted		

3.4.2 Set Device Invert

Controller:

(CC) SET_COMMAND	(PID) Device Invert = 0x8006	(PDL) 0x01
(PD) BYTE[0] 0: Normal, 1: Inverted		

Responder:

(CC) SET_COMMAND_RESPONSE	(PID) Device Invert = 0x8006	(PDL) 0x00
(PD) Not Present		

3.5 PWM Dithering

Parameter ID **0x8007**. This parameter changes the frequency from 400Hz to 1200Hz outputting an approximated 16-bit curve.

3.5.1 Get PWM Dithering

Controller:

(CC) GET_COMMAND	(PID) Device Dither = 0x8007	(PDL) 0x00
(PD) Not Present		

Responder:

(CC) GET_COMMAND_RESPONSE	(PID) Device Invert = 0x8007	(PDL) 0x01
(PD) BYTE[0] 0: 400Hz Standard 1: 1200Hz Dithered		

3.5.2 Set PWM Dithering

Controller:

(CC) SET_COMMAND	(PID) Device Invert = 0x8007	(PDL) 0x01
(PD) BYTE[0] 0: Standard, 1: Dithered		

Responder:

(CC) SET_COMMAND_RESPONSE	(PID) Device Invert = 0x8007	(PDL) 0x00
(PD) Not Present		

3.6 Device Start-up Level

Parameter ID **0x8008**. This parameter sets the device start-up mode for DMX. The default start-up for DMX is all channels off, however this can be set to any level from 0-254, with 255 as 'last level'.

3.6.1 Get Device Start-up

Controller:

(CC) GET_COMMAND	(PID) Device Start Up = 0x8008	(PDL) 0x00
(PD) Not Present		

Responder:

(CC) GET_COMMAND_RESPONSE	(PID) Device Start Up = 0x8008	(PDL) 0x01
(PD) BYTE[0] 0-254: Level Set. 255: Resume last level received		

3.6.2 Set Device Start-up

Controller:

(CC) SET_COMMAND	(PID) Device Invert = 0x8008	(PDL) 0x01
(PD) BYTE[0] Current Set Level		

Responder:

(CC) SET_COMMAND_RESPONSE	(PID) Device Invert = 0x8008	(PDL) 0x00
(PD) Not Present		

3.7 Device Global Max

Parameter ID **0x8009**. This parameter sets the global device maximum. No channel will be set above the global maximum.

3.7.1 Get Device Max

Controller:

(CC) GET_COMMAND	(PID) Device Invert = 0x8009	(PDL) 0x00
(PD) Not Present		

Responder:

(CC) GET_COMMAND_RESPONSE	(PID) Device Invert = 0x8009	(PDL) 0x01
(PD) BYTE[0] 0-255 – Global Max		

3.7.2 Set Device Max

Controller:

(CC) SET_COMMAND	(PID) Device Invert = 0x8009	(PDL) 0x01
(PD) BYTE[0] Global Max Level		

Responder:

(CC) SET_COMMAND_RESPONSE	(PID) Device Invert = 0x8009	(PDL) 0x00
(PD) Not Present		

3.8 Device Global Min

Parameter ID **0x800A**. This parameter sets the device global minimum. The minimum is the lowest output from the SLAMMO before switching to OFF. This can be used for LED which does not perform at lower voltages.

3.8.1 Get Device Min

Controller:

(CC) GET_COMMAND	(PID) Device Invert = 0x800A	(PDL) 0x00
(PD) Not Present		

Responder:

(CC) GET_COMMAND_RESPONSE	(PID) Device Invert = 0x800A	(PDL) 0x01
(PD) BYTE[0] 0-255 – Global Min		

3.8.2 Set Device Min

Controller:

(CC) SET_COMMAND	(PID) Device Invert = 0x800A	(PDL) 0x01
(PD) BYTE[0] Global Min Level		

Responder:

(CC) SET_COMMAND_RESPONSE	(PID) Device Invert = 0x800A	(PDL) 0x00
(PD) Not Present		

Glands

The SLAMMO V5 - in IP54 and IP67 versions - is supplied with four off M20 glands that are suitable for cables with an OD of 6 to 12mm. If the cable diameter (eg for DMX) is smaller, insert the separate reducing seal which will change the gland to suiting 5 to 9mm OD cables. Also supplied with the IP54 version is an M20 blind screw for applications where only 3 of the 4 possible glands are needed.

Always leave enough cable length to be able to easily connect to cables during servicing, testing and commissioning. When using Cat 6e and similar cables for DMX, insert the cable through the gland and use a crimp on RJ connector.

Always use circular cables with the glands – figure 8 and other non-circular cables will not seal properly inside the glands.

Position the glands to minimise cable bending radii – too tight a bend due the location of the gland can damage cables internally. Note that in the IP67 version, the lid (either end) can also be used for cable entry if required.

In non-exposed locations, the installer may elect to reduce the IP rating and leave the glands out, however note that the glands also provided mechanical restraint to cables such that they do not pull free accidentally or allow excessive mechanical stress on the termination blocks and DMX sockets. In the IP54 version, care should be taken with cable management so that the cables exit straight so that they do not put undue mechanical strain on the end plugs.

Always ensure that output cables are sized to minimise voltage drop. A VDC drop of <1VDC is recommended, 0.5VDC max preferred.

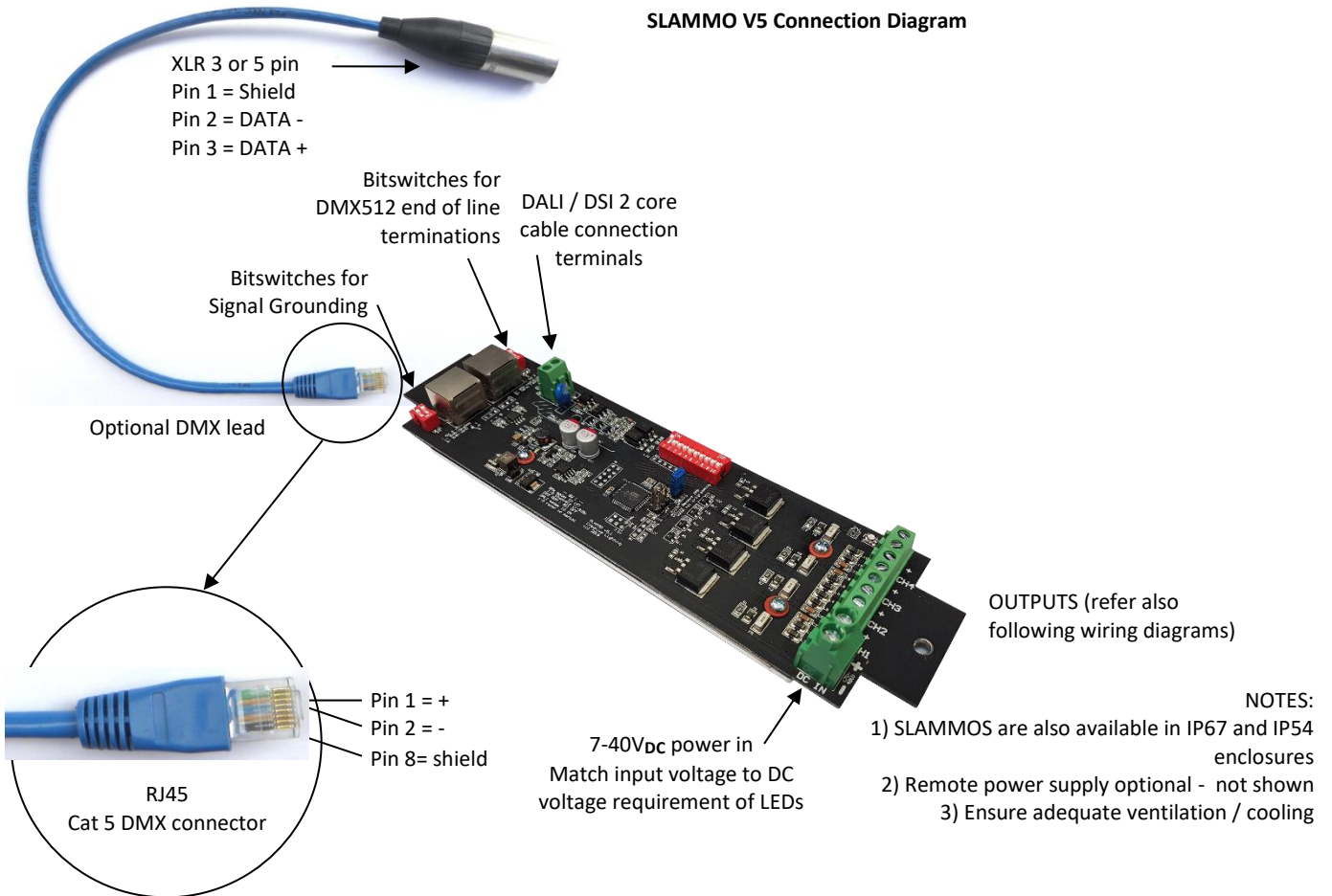

Specifications

Description	Details
Dimming Type	Pulse width modulation suits common anode bias-resisted LEDs
Physical	
Size (l) x (w) x (h) mm	PCB 235x67x29. Enclosed (without glands) 268x97x48 Enclosed (with glands) 324x97x48
Weight (kg)	PCB ~0.15. Enclosed ~0.74.
Power	
DC Input	7-60V _{DC} -(48V _{DC} max recommended) match to requirement of LEDs
DC Output	7-60V _{DC} -(48V _{DC} max recommended) dependent upon input voltage.
Maximum load	In <40 degC max environments (de-rate for hotter environments): PCA - 10A per channel (load outputs as evenly as possible), 25A total IP54 – 600W @ 24VDC / 400W@ 12VDC IP67 - 450W @24VDC / 300W @12VDC NOTE: The power supply must be CISPR15/EN55015 compliant. Allow to derate the power supply to suit the LED inrush current (as a general rule, a minimum of 15% derating is recommended for Meanwell HLG series power supplies)
Protection	Immune from accidental DC input reversal Short-circuit protection 15A fuses on all channels (outputs) and 500mA self-resetting polyfuse to DC input Transient protection to DMX transceiver and DC input DALI: Over-voltage /spike protection and mains overvoltage
Data Protocols	DALI, DMX512, DSI, RDM
Site considerations – important!	Ensure that adequate air movement and or cooling is provided to maintain SLAMMO V5 board temperature at or below 70°C
EMC	Complies with CISPR15. CE. C Tick / RCM

Cable Glands & mounting – IP67 enclosed models only



SLAMMO V5 - in IP54 and IP67 versions - is supplied with four off M20 glands that are suitable for cables with an OD of 6 to 12mm. If the cable diameter (eg for DMX) is smaller, insert the separate reducing seal which will change the gland to suiting 5 to 9mm OD cables. Also supplied with the IP54 version is an M20 blind screw for applications where only 3 of the 4 possible glands are needed.

Note that it is recommended that the SLAMMO is mounted horizontally. If the SLAMMO is mounted vertically (e.g. in a pole) then the model selected should be IP67 and all glands should be located on the bottom side as shown in the picture at left.

The DMX cables, if used, must be terminated with a crimp RJ45 once cable is routed into the IP67 enclosure.

Note that all cables used must be circular and only one cable may be used per cable entry gland.

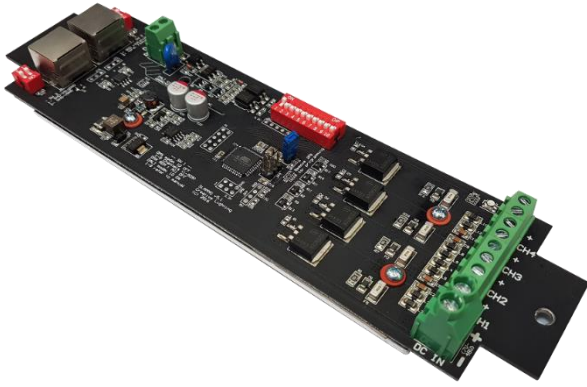

SLAMMO v5 PCA



SLAMMO v5 in an IP54 Enclosure



SLAMMO v5 in an IP67 Enclosure

Example wiring schematics

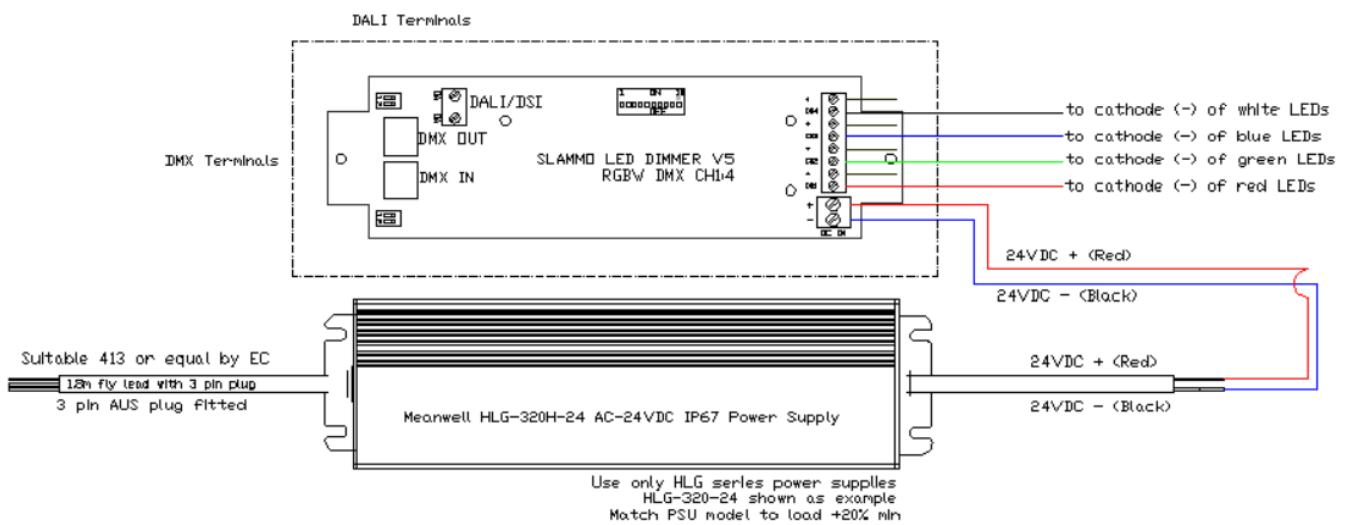

Warranty

Refer to the Creative Lighting Warranty Statement